

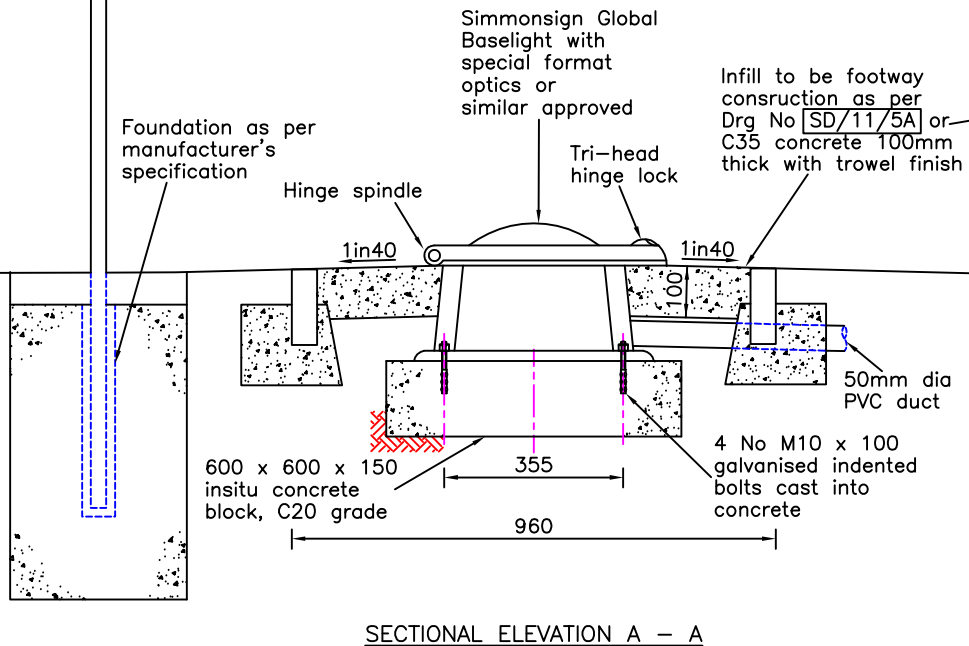

Leicestershire
County Council

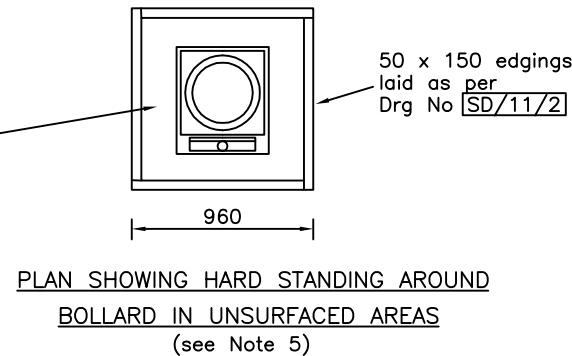

- NOTES:
- All dimensions are in millimetres unless otherwise stated.
 - The base light enclosure shall be manufactured in cast aluminium LM6-M grade and incorporate a bollard platform hinged on a one piece stainless steel pin running in stainless steel bushes.
The hinged platform shall be lockable by a tri-head stainless steel bolt and cast in thread. The bolt head to be rebated to resist unauthorised entry. The platform shall retain and seal a 5mm thick UV stabilised polycarbonate domed lens to a protection factor of IP67 (BS 5490). Removal of the lens shall operate a double pole insulator switch.
A removable gear tray housed in the enclosure and manufactured from non-corrodible material shall have a bonded incoming supply plug which shall engage in the order of earth, neutral then live and disconnect in the reverse. Clipped to the tray shall be 2No PL 11 watt fluorescent tubes mounted over a highly polished twin parabolic reflector.
The enclosure should allow an existing board cut-out to be entered and efficiently sealed with any board/private loop cables to a protection factor of IP68.
 - The foundation incorporating the ducting should be as per the manufacturers recommendations.
 - Where the bollard is installed in an unsurfaced verge or island, the bollard base must be surrounded by an area of hard surfacing as shown.
 - The bollard should be positioned 0.5m to 1m from the front face of the 'CHEVROFLEX'. A clearance of 0.45m to 0.6m from the carriageway to the side faces of the bollard shall be maintained or as agreed with the Engineer.

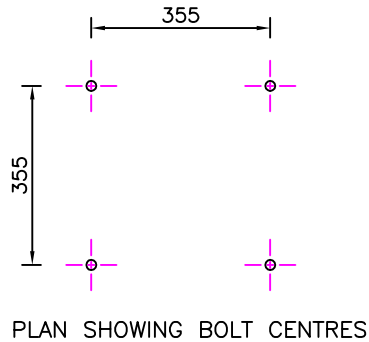
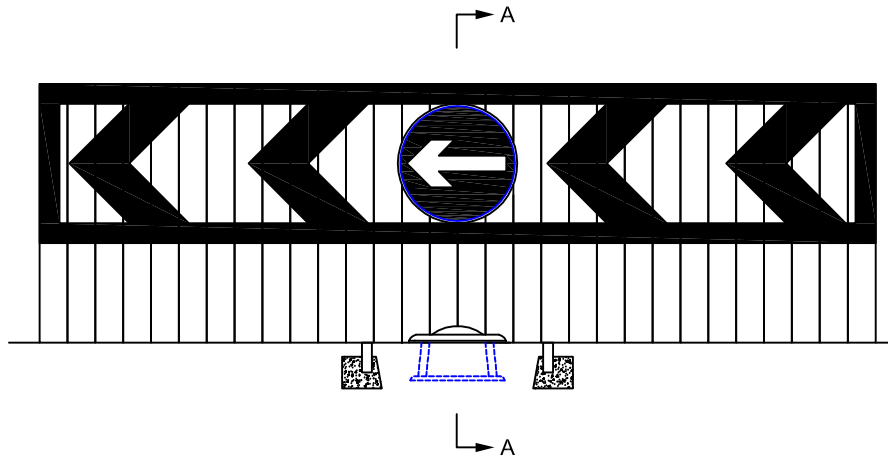

Leicestershire
County Council

© Crown copyright 2007. All rights reserved. Use of this image is limited to viewing on-line and printing one copy. Leicestershire County Council. 100619271.

DRAWING NUMBER	DATE			
SD/12/40	APRIL 2007			
AUTOCAD REF	SCALE			
K:\GENERAL\ID9997\STDDRG\SD1240	NOT TO SCALE	Rev	Date	Notes on Revision